

Autonics Digital Pressure Sensor (fluid type) PSAN Series

INSTRUCTION MANUAL



Thank you very much for selecting Autonics products.
For your safety, please read the following before using.

Safety Considerations

- Please keep these instructions and review them before using this unit.
- Please observe the cautions that follow:
- Warning** Serious injury may result if instructions are not followed.
- Caution** Product may be damaged, or injury may result if instructions are not followed.
- The following is an explanation of the symbols used in the operation manual.
- Caution:** Injury or danger may occur under special conditions.

- Fail-safe device must be installed when using the unit with machinery that may cause serious injury or substantial economic loss. (e.g. nuclear power control, medical equipment, ships, vehicles, railways, aircraft, combustion apparatus, safety equipment, crime/disaster prevention devices, etc.)
- Failure to follow this instruction may result in fire, personal injury, or economic loss.
- Install on a device panel or to a pressure port directly to use.
- Failure to follow this instruction may result in fire.
- Do not connect, repair, or inspect the unit while connected to a power source.
- Failure to follow this instruction may result in fire.
- Check 'Connections' before wiring.
- Failure to follow this instruction may result in fire.
- Do not disassemble or modify the unit.
- Failure to follow this instruction may result in fire.

Caution

- Use the unit within the rated specifications.
- Failure to follow this instruction may result in fire or product damage.
- Use dry cloth to clean the unit, and do not use water or organic solvent.
- Failure to follow this instruction may result in fire.
- This product is designed to detect the pressure of noncorrosive gas/liquid.
- Do not use for corrosive gas/liquid.
- Failure to follow this instruction may result in product damage.
- Do not use the unit in the place where flammable/explosive/corrosive gas, humidity, direct sunlight, radiant heat, vibration, impact, or salinity may be present.
- Failure to follow this instruction may result in fire or explosion.
- Keep metal chip, dust, and wire residue from flowing into the unit.
- Failure to follow this instruction may result in fire or product damage.

Dimensions

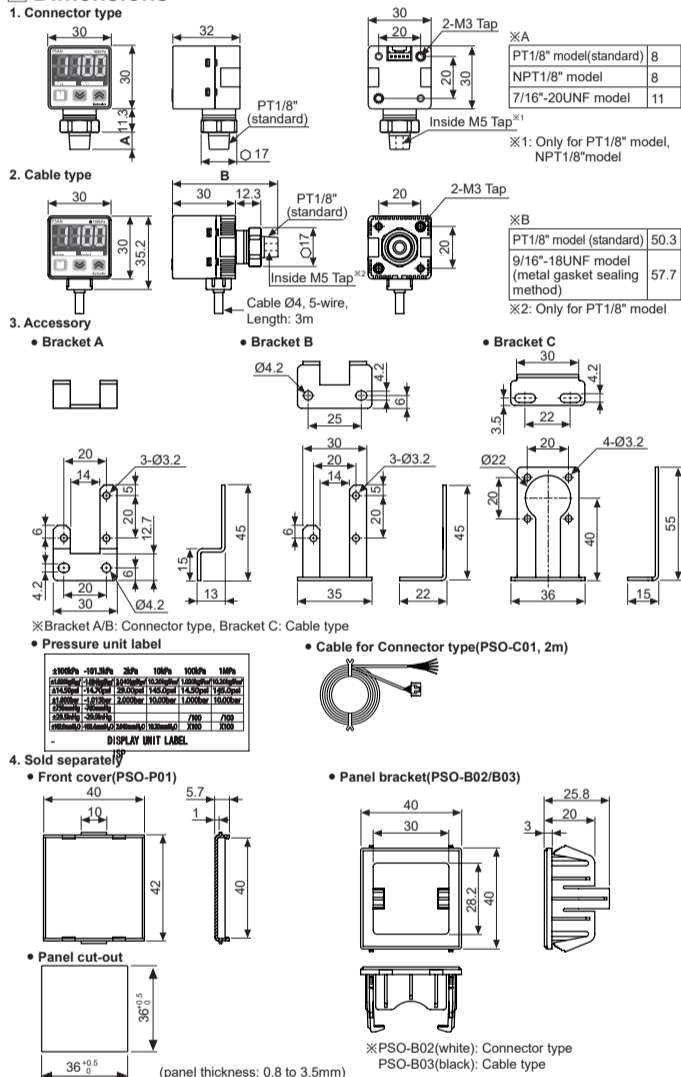

Functions

- Pressure unit change** PSAN-LV01C(P) and PSAN-LC01C(P) has 7 kinds of pressure unit, PSAN-L01C(P) and PSAN-L1C(P) has 5 kinds of pressure unit. Please select the proper unit for application.
- Output mode change** There are 5 kinds of control output mode in order to realize the various pressure detection.
- Control output change** Type of control output for OUT1 and OUT2 can be able to set Normally Open and Normally Closed.
- Response time change (Chattering prevention)** It can prevent chattering of control output by changing response time.
- Analog output scale setting and Hold/Auto Shift setting**
- Key lock** The key lock prevents key operations so that conditions set in each mode. [preset/parameter mode are not inadvertently changed. There are 2 kinds of key lock functions available.
- Zero point adjustment** The zero point adjustment function forcibly sets the pressure value to "Zero" when the pressure port is opened to atmospheric pressure.
- High Peak / Low Peak Hold** This function is to diagnosis malfunction of the system caused by parasitic pressure or to check through memorizing the max./min. pressure occurred from the system.

Error

Display	Description	Troubleshooting
Err1	When external pressure is input while adjusting zero point.	Try again after removing external pressure.
Err2	When overload is applied on control output	Remove overload.
Err3	When setting condition is not met in Auto sensitivity setting mode	Check setting conditions and set proper set values.
LLL	When applied pressure exceeds Low-limit of display pressure range.	Apply pressure within display pressure range.
HHH	When applied pressure exceeds High-limit of display pressure range.	Apply pressure within display pressure range.
-H/-L/-L/-L	Auto shift correction error.	Set the corrected set value within setting pressure range.

The above specifications are subject to change and some models may be discontinued without notice.
Be sure to follow cautions written in the instruction manual and the technical descriptions (catalog, homepage).

Specifications

Pressure type	Sealed gauge pressure ^(*) (In case of 100.0kPa/Standard pressure is gauge pressure.)			
	Negative pressure	Standard pressure	Compound pressure	Compound pressure
Voltage output	PSAN-LV01C(P)-V	PSAN-L01C(P)-V	PSAN-L1C(P)-V	PSAN-LC01C(P)-V
Current output	PSAN-LV01C(P)-A	PSAN-L01C(P)-A	PSAN-L1C(P)-A	PSAN-LC01C(P)-A
Hold/Auto shift input	PSAN-LV01C(P)-H	PSAN-L01C(P)-H	PSAN-L1C(P)-H	PSAN-LC01C(P)-H
Rated pressure range	0.0 to -101.3kPa	0.0 to 100.0kPa	0 to 1,000.0kPa	-101.3kPa to 100.0kPa
Display pressure range	5.0 to -101.3kPa	-5.0 to 110.0kPa	-101.3 to 1,100kPa	-101.3kPa to 110.0kPa
Min. display unit	0.1kPa	0.1kPa	0.1kPa	0.1kPa
Max. pressure range	2 times of rated pressure			
Applied fluid	Air, Non-corrosive gas and fluid that will not corrode SUS316L			
Power supply	12V-24VDC ± 10% (ripple P-P: Max. 10%)			
Current consumption	Max. 50mA (Analog Current Output type Max 75mA)			
Control output	NPN or PNP open collector output			
Hysteresis ^(**)	Min. display range			
Repeat error	±0.2% F.S. ± Min. display range			
Response time	Selectable 2.5ms, 5ms, 100ms, 500ms, 1000ms			
Short circuit protection	Built-in			
Analog output	Voltage output			
	Current output			
Display method	7segment LED Display			
Resolution	1000	2000	1000	2000
Pressure unit	MPa	0.001	0.001	0.001
kPa	0.1	0.1	1	0.1
kgf/cm ²	0.001	0.001	0.01	0.001
bar	0.001	0.001	0.01	0.001
psi	0.01	0.01	0.1	0.02
mmHg	0.4	0.4	4	0.8
inHg	0.02	0.02	0.2	0.03
mmH ₂ O	0.1	0.1	1	0.1
Display accuracy	0°C to 50°C: Max. ±0.5% F.S., -10 to 0°C: Max. ±1% F.S.			
Dielectric strength	1000VAC 50/60Hz for 1 minute			
Insulation resistance	Over 50MΩ (at 500VDC megger)			
Vibration	1.5mm amplitude at frequency of 10 to 55Hz (for 1 min.) in each of X, Y, Z direction for 2 hours			
Environ. Ambient temp.	-10 to 50°C, storage: -20 to 60°C			
ment Ambient humi.	30 to 80%RH, storage: 30 to 80%RH			
Protection	Connector type: IP40 (IEC standards), Cable type: IP65 (IEC standards)			
Material	Front case: PC, Rear case: PA6, Pressure port: SUS316L			
Cable	Connector cable (Ø4, 5-wire, Length: 2m) (AWG24, Core diameter: 0.08mm, Number of cores: 40, Insulator out diameter: Ø1mm)			
Approval	CE			
Weight	Connector type: Approx. 173g (approx. 88g), Cable type: Approx. 167g (approx. 90g)			

- *1: (P) is PNP output type, (V) of model name is as pressure port.
- R1/8: PT1/8" model (standard), NPT1/8: NPT1/8" model, 9/16"-18UNF: 9/16"-18UNF model (cable type), 7/16"-20UNF: 7/16"-20UNF model (connector type)
- **2: In hysteresis output mode, detection difference is variable.
- **3: It is allowed to select one analog output type only.
- **4: Resolution/1000/2000 of min. display interval is automatically selected by pressure units.
- **5: This weight is with packaging and the weight in parentheses is only unit weight.
- **6: The unit is sealed structure. It is based on atmospheric pressure 101.3kPa.

Unit Descriptions

- Range of rated pressure: It is possible to change the pressure unit in Pressure sensor. Please use different unit as label for your application.
- 4digit LED display (Red): Used to indicate measured pressure value, set value and error message.
- Output indicator (Red): Output 1 is ON, LED will be ON.
- Output indicator (Green): Output 2 is ON, LED will be ON.
- Key: Used to enter into Preset/Parameter setting mode and to save Setting mode.
- Key: Used to set parameter and preset, peak value check mode, function setting or output operation mode.
- Key: Used for zero point adjustment function by pressing key over 1 sec. Simultaneously in RUN mode.

Output Operation Mode

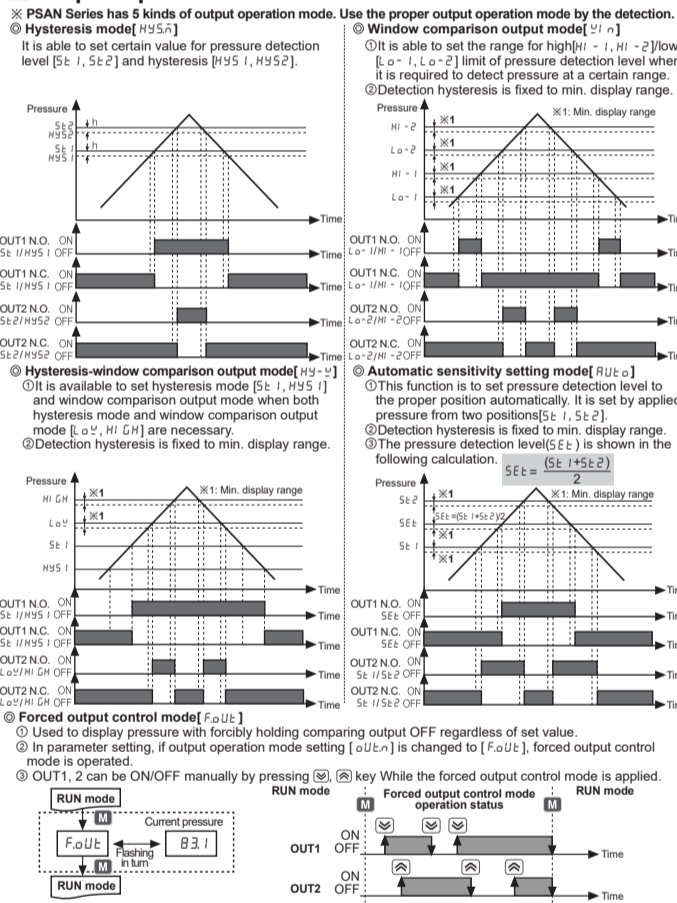

Control Output and Connection Diagram

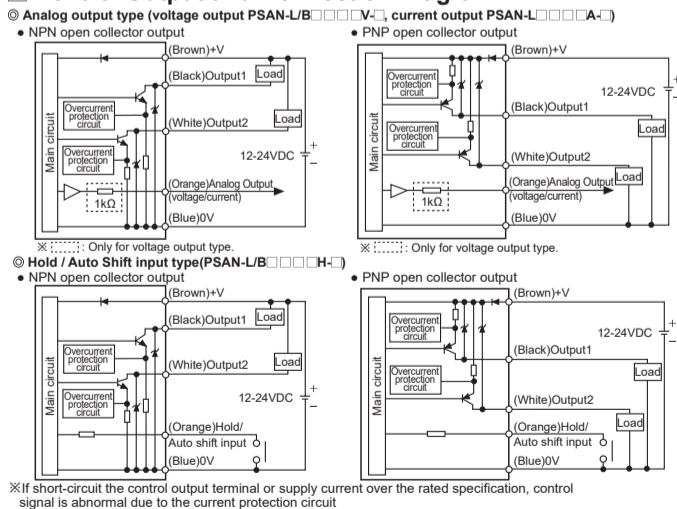

Installation

- Pressure port is divided as basic and option specification. Therefore, be sure that to use commercially available one touch fitting (Standard: RPT1/8", Option: NPT1/8", 9/16"-18UNF, 7/16"-20 UNF)
- Please connect it by using spanner (17mm) at the metal part in order not to overload on the body when connecting one touch fitting.
- PSAN Series provides 2 brackets for connector type, 1 bracket for cable type. The 2 types of installation is available for installation environments.
- At first, please unscrew hexagon wrench bolt and assemble the bracket on this unit by fixing hexagon the wrench bolt. In this case, tightening torque of hexagon wrench should be max. 3N·m. It may cause mechanical problems.

Caution

- The tightening torque of one touch fitting should be max. 10N·m. It may cause mechanical problems.
- Do not pull the cable with a tensile strength of 30N or over.

Setting

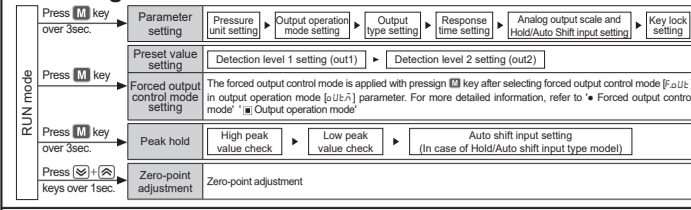

Parameter Setting

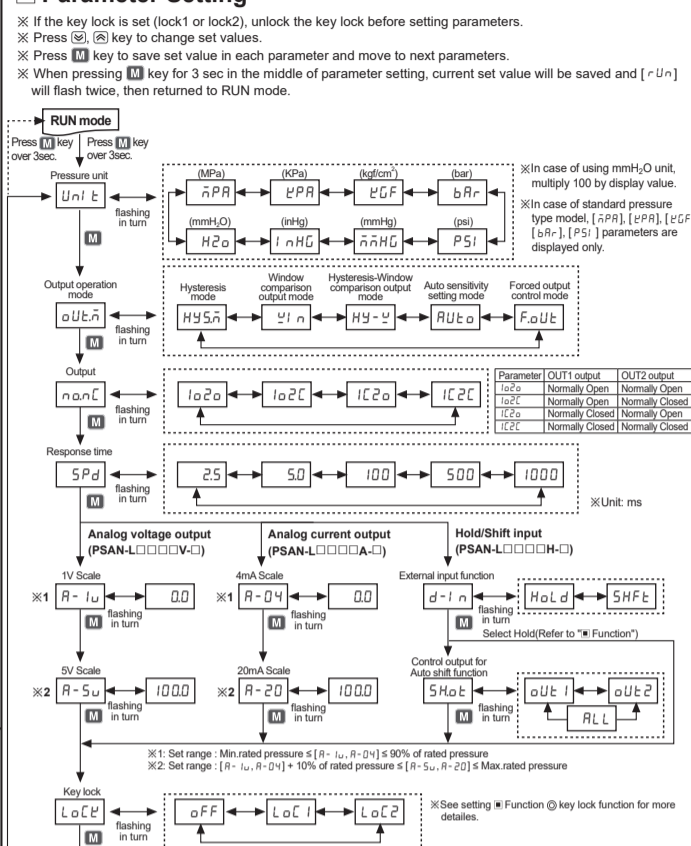

Preset Setting

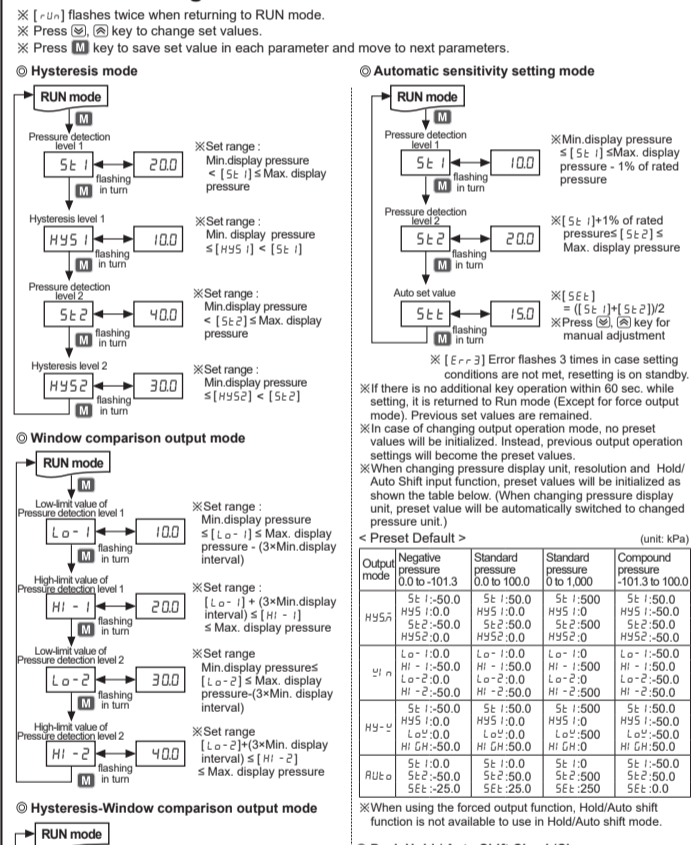

Major products

- Photoelectric Sensors
 - Temperature Controllers
 - Fiber Optic Sensors
 - Temperature/Humidity Transducers
 - Door Sensors
 - SSR/Power Controllers
 - Side Sensors
 - Counters
 - Area Sensors
 - Panel Meters
 - Proximity Sensors
 - Pressure Sensors
 - Rotary Encoders
 - Pressure Sensors
 - Encoder/Decoder
 - Graphical/Logic Panels
 - Control Switches/Amplifiers
 - Field Network Devices
 - Graphical/Logic Panels
 - Control Switches/Amplifiers
 - Switching Mode Power Supplies
 - Laser Marking System (Fiber, CO₂, Nd:YAG)
 - Laser Welding/Cutting System
 - Temperature Controllers
 - Temperature/Humidity Transducers
 - SSR/Power Controllers
 - Counters
 - Panel Meters
 - Pressure Sensors
 - Rotary Encoders
 - Encoder/Decoder
 - Graphical/Logic Panels
 - Control Switches/Amplifiers
 - Switching Mode Power Supplies
 - Laser Marking System (Fiber, CO₂, Nd:YAG)
 - Laser Welding/Cutting System
- Autonics Corporation**
http://www.autonics.com
- HEADQUARTERS:
18, Bongsong-ro 513 beon-gil, Haundae-gu, Busan, South Korea, 48002
TEL: 82-51-519-3232
E-mail: sales@autonics.com