

E 2 Series Mini square type Photo sensor

CE RoHS

- Solid compact structure :
12x30x17 (WxHxD mm)
- Protection class : IP-66
- Output status NO / NC changeable
- Polarized mirror reflex type available
- Transparent object detectable



◆ General Specification / 共同規格

Type	Diffuse Reflex		Mirror Reflex			Thru Beam
Model	E2R-10N	E2R-30N	E2G-2MN	E2G-1MRE	E2G-1MG	E2T-4MN
Sensing distance	10cm	30cm	2.0m	1.2m	1.2m	6.0m
Emitter	Infrared LED		Red LED		Green LED	Infrared LED
Current consumption 耗電流	30 mA max.		25 mA max.			40 mA max.
Response time 應答時間	1 ms max.					
Operating voltage 工作電壓	10 ~ 30VDC					
Ripple of power 電源漣波	20% peak to peak					
Output method 輸出方式	NPN NO/NC changeable					
Output current 輸出電流	150mA max.					
Residual voltage 殘留電壓	0.1V max.					
Leakage current 洩露電流	0.8mA max.					
Protection circuit 保護電路	Short circuit & polarity reversed protection					
Housing material 外殼材質	Intensive PBT					
Illumination 耐外亂光	Lamp light < 10,000Lux ; Sunlight < 20,000Lux					
Noise resistance 抗干擾	2kv/1μs					
Dielectric strength 電介強度	2.5kv / 1 minute min.					
Insulation strength 絕緣強度	100 MΩ / 500vdc					
Operating circum. 工作環境	-25°C ~ +80°C ; 35% ~ 85% RH					
Protection class 保護等級	IP-66					
Approval 認證	CE Rohs					

◆ Output circuit & Connection diagram / 輸出回路及接線圖

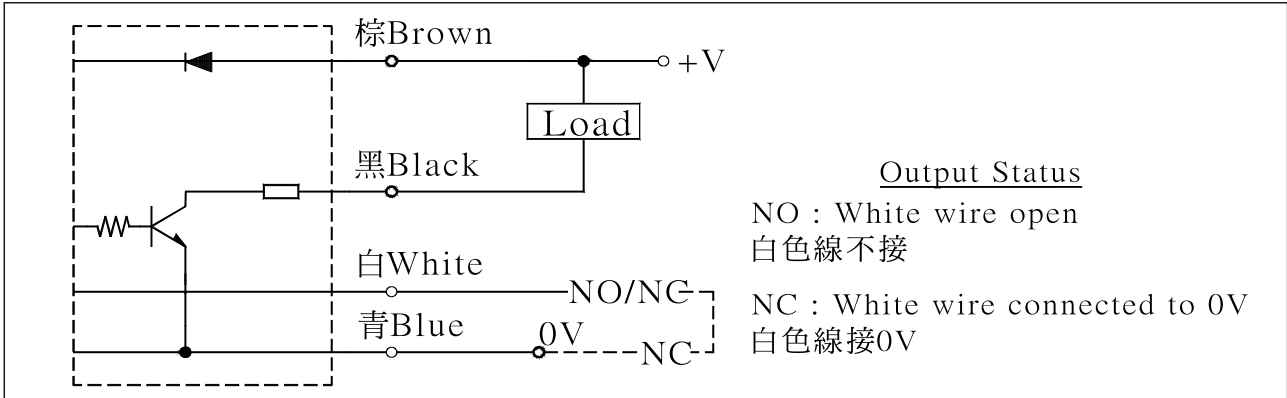

◆ Dimension / 外形尺寸圖

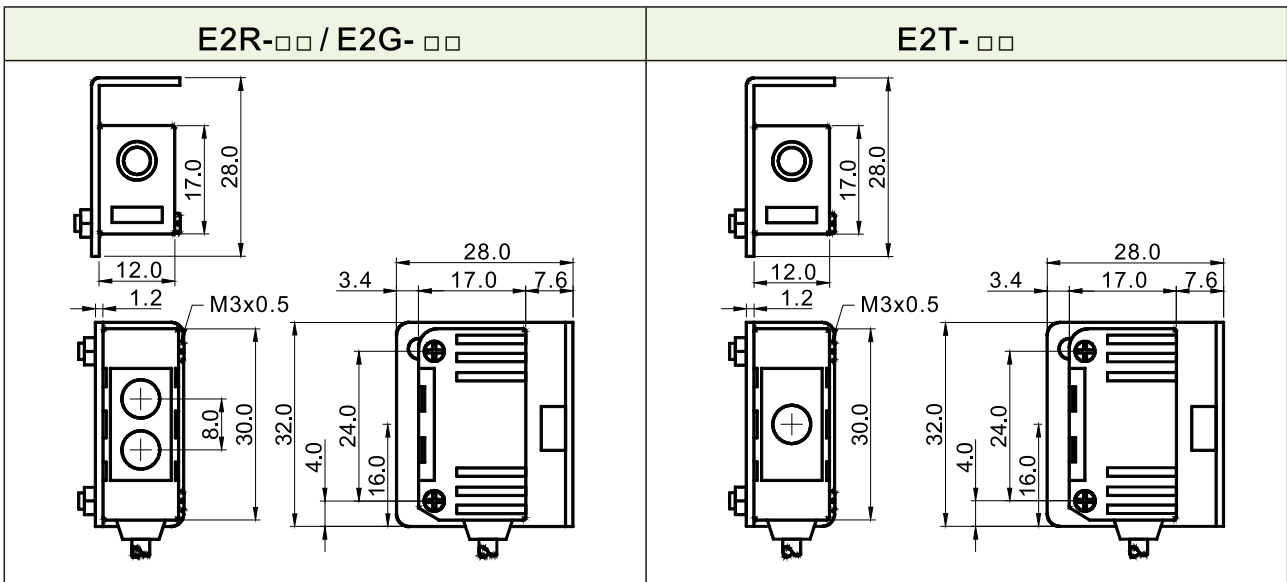

◆ Fixed bracket / 固定架

